

Embedded/External Mesh Rider® Radio – 1350~1390 MHz

Overview

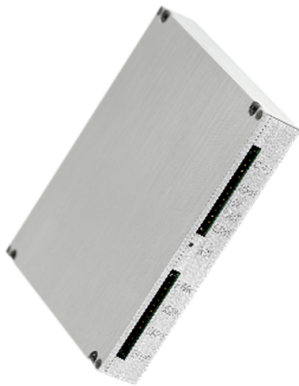

Embedded



External

The Mesh Rider® Radio is an advanced 2x2 MIMO mesh router designed for easy plug & play integration. The tiny module carries all bi-directional communication (e.g. Telemetry, Video) in a single high-speed broadband RF channel.

Due to its very low SWaP-C (Space, Weight and Power and Cost), the Mesh Rider® Radio is very popular for mobile IIoT (Industrial Internet of Things) applications like drones, autonomous vehicles, and mobile robotics applications across various industries.

The Mesh Rider® Radio employs Doodle Labs' patented Mesh Rider® technology with state-of-the-art RF and networking capabilities that enable communication further, faster, and more reliably than any comparable solution on the market. For example, the Ultra Reliable Low Latency Channel (URLLC) transports important command and control data over the wireless link, while a concurrent video-optimized streaming channel carries crystal clear 4K video.

The Mesh Rider® Radio is available in many frequency bands between 100 MHz and 6 GHz in form-factor compatible models. This allows customers to switch the operating band by simply swapping the radio module, avoiding costly re-design efforts when expanding to new markets that require new frequencies. The Mesh Rider® Radio is available in embedded and external form factors.

For more information, please visit: <https://doodlelabs.com/Mesh-Rider-radio/>

Samples available on Mouser: [https://www.mouser.com/search/refine.aspx?
N=4248121056](https://www.mouser.com/search/refine.aspx?N=4248121056)

Key Features - Mesh Rider® Radio Platform

PERFORMANCE RF

- Long range (field tested >100km) and high throughput (up to 100 Mbps) Mesh Rider waveform
- Interference resistant COFDM for robust link quality in difficult RF environments
- Exceptional Multipath and NrLOS MIMO performance
- Adaptive radio modulations from BPSK up to 64QAM, with fast per packet optimization to maximize link performance in dynamic environments
- Software defined channel bandwidth for efficient re-use of spectrum
- Convolutional coding, Forward Error Correction (FEC), ACK-retransmits, Maximal Ratio Combining, Spatial Multiplexing, and Space Time Block Coding for robust data transmission over noisy channel/spectrum
- Single channel, Time Division Duplexing (TDD) for bi-directional traffic
- Resistant to high-power jamming signals
- ATPC for widely dispersed mesh network
- Built-in Spectrum Scanner to help mitigate interference issues

PERFORMANCE NETWORKING

- Ultra-Reliable Low Latency Channel (URLLC) for Command and Control
- Optimized video streaming channel for Unicast and Multicast transport
- Self-healing/self-forming multi-frequency mobile mesh for highly reliable network with redundancy
- FIPS Certified AES 256- and 128-bit encryption
- End-to-end IP architecture with Ad Hoc, WDS transparent bridge, Client, AP, and Internet Gateway operating modes
- Embedded network management APIs

ADDITIONAL FEATURES

- Very small size, weight, and power for mobile applications
- Ethernet, USB, and UART interfaces to allow easy integration into different system architectures
- Leverage the benefits of the most extensible OpenWrt ecosystem and install 3rd party IoT applications
- Rugged, vibration resistant construction to meet MIL-specs
- MIL-spec temp range (-40C to +85C)
- High quality, manufactured in ISO 9001 and ISO 14001 certified facilities
- COTS – Commercial off the Shelf
- Extended lifespan and availability

Band Introduction – 900 MHz ISM Band

The 1370 MHz band ranges from 1350~1390 MHz. This band's transmission characteristics make it desirable to achieve a good balance of range and penetration for mobile ground-based robots. The RF signals at 1370 MHz have the ability to propagate further distances via two mechanisms: penetration and diffraction. Penetration refers to 1370 MHz waves ability to penetrate through building walls, vegetation and other obstacles. 1370 MHz waves can go through multiple building walls making it an excellent choice for applications that do not have a direct line of sight between sender and receiver. Diffraction describes the characteristic of a 1370 MHz wave that it can go around an object such as a building or vegetation. 1370 MHz waves have smaller Fresnel zone.

The DoD operates telemetry systems in this band that are used to transmit and receive data from airborne vehicles at test and training ranges. Additionally, the DoD operates transportable tactical point-to-point communication systems in the 1370 MHz band. These tactical communication systems are used for command and control networks for military ground forces. This is the only transmission media available to the Marine Corps with sufficient bandwidth to carry large quantities of critical data such as maps, overlays, intelligence pictures, and other data to the battlefield commanders. These systems are used within the United States for comprehensive and realistic training to maintain a high level of combat readiness. The DoD will continue to operate tactical transportable fixed point-to-point communication systems in this band for the foreseeable future.

System Integration

The Mesh Rider® Radio is an embedded module. It has been designed to be nearly plug and play. Only Ethernet, power supply (5.5~42V), and antenna connections are required for integration.

Doodle Labs provides the following documents upon request: integration guide, 3D CAD model, mechanical drawing, cable drawing, and thermal map.

Visit [Doodle Labs Technical Library](#) for extensive design-in documents.

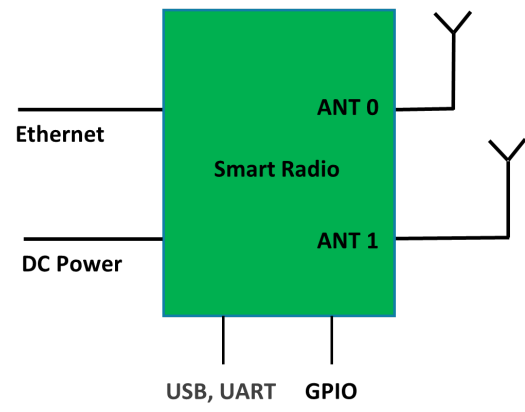

Technical Specifications (1350~1390 M)

Model Category	XTreme
ORDERING CODES	
Radio Configuration	2x2 MIMO
Model # (v3 hardware)	RM-1370-2J-XM (Embedded, Industrial temp) RM-1370-2J-XM-C (Embedded, Commercial temp) RM-1370-2J-XE (External, Industrial temp) RM-1370-2J-XE-C (External, Commercial temp)
Model options	Integrated GPS – add G suffix PoE (External only) – add O suffix
Evaluation Kit (Optional)	EK-1370-2J (Ethernet board for Embedded model)
Design-In Documentation	Doodle Labs Technical Library
PERFORMANCE OVERVIEW	
Data Throughput at 10-meter range with Attached 3 dBi Antennas (Indicative)	80 Mbps (20 MHz Channel) 40 Mbps (10 MHz Channel) 20 Mbps (5 MHz Channel) 12 Mbps (3 MHz Channel)
Over the Air Data Encryption	128-bit AES (Full throughput) 256-bit AES (12 Mbps max throughput)
FIPS Certification (Optional)	FIPS 140-3
Operating Modes	Mesh, WDS AP, WDS Client Bridged or Internet Gateway with NAT
Command & Control channel	Ultra-Reliable Low Latency Channel (URLLC). Latency 1.5-10 ms

Video Channel	Optimized video streaming with Unicast and Multicast transmission
RF SPECIFICATIONS	
Protocol Compatibility	Fully compatible with Doodle Labs Mesh Rider Waveform
Frequency Range	1350-1370 MHz
Advanced Band Filters	Dedicated SAW filters for high interference immunity
Max RF Power at SMA port (Software control) Each radio individually calibrated	1.0W (30 dBm) @ MCS 0,8 0.8W (29 dBm) @ MCS 3,11 0.4W (26 dBm) @ MCS 5,13 250mW (24 dBm) @MCS 7,15
Channel Sizes (Software Selectable)	3, 5, 10, 20 MHz
Radio Data Rate	Auto adapting Modulation Coding Scheme (MCS0-15)
Antenna Signal Strength	-25 to -85 dBm (Recommended), Absolute Maximum= +12 dBm
RF Power Control	In 1 dBm steps, Tolerance ± 1 dBm
Automatic Transmit Power Control (ATPC)	Intelligently adjusts the transmit power for very close range operation
Integrated Antenna Port Protection	Able to withstand open port, >10 KV (contact) and >15KV (open air discharge) as per IEC-61000-4-2
Wireless Error Correction	FEC, ARQ
Receive Noise Figure	+4 dB
Receive Adjacent Channel Rejection (ACRR)	34 dB @ MCS0 for 20 MHz channel (Typ)

Transmitter Adjacent Channel Leakage Ratio (ACLR)	< 28 dBr (Fc ± ChBW)
Transmitter Spurious Emission Suppression	< 55 dBc
Frequency Accuracy	±10 ppm max over life
Control for External Power Amp	DC biased signal over RF port
NETWORKING SPECIFICATIONS	
Mesh Router	Self-Forming/Self-Healing, Peer to Peer
Custom Software Package Manager	Image Builder, OPKG, ipk
Radio Management	Web GUI (HTTPs), SSH and JSON-RPC
Access control	Password, MAC, IP, Port filtering
Supported Protocols	IPv6, QoS, DNS, HTTPS, IP, ICMP, NTP, DHCP
Software Upgrade	Over the air software upgrade supported
HARDWARE SPECIFICATIONS	
Case Material	Aluminum (Embedded & External)
Power Input	6V - 42V DC (EOL August 2022) 6V - 32V DC External supports passive POE
DC Power Consumption	10W @ Max RF power in UDP data Tx mode 4W in Rx mode 1.2W in Standby mode

Dimensions	65 x 57 x 12 mm, 78 grams (Embedded) 148 x 137 x 58 mm, 540 grams (External)
Mesh Rider Antenna Ports	2x MMCX-Female (Embedded) 2x SMA-Female (External)
Host Interface	2x Ethernet (100 Base-T), 1x UART (3.3V), 2x USB 2.0 Host, 2x GPIO (Embedded) 2x Ethernet (100 Base-T), 1x UART (RS232), 2x USB 2.0 Host, 2x GPIO (External)
Temperature range (Operating)	Industrial: -40°C to +85°C, Commercial: -10°C to +65°C <i>* System's thermal design should ensure that the radio's case temperature is maintained within these specifications.</i>
Ingress Protection	IP 50 (Embedded), Dust Protected, No Liquids IP66 — Protected from high pressure water jets from any direction.
Relative Humidity	5% to 95% non-condensing
Shock and Vibration Resistance	Compliant to MIL-STD-810H for high shock and vibration
Reliability	Extreme Reliability, IPC Class 2 standard with Class 3 options
Integrated GPS (optional)	Simultaneous multiple constellations (GPS/Galileo/Glonass/BeiDou/QZSS), 1.5 meter CEP position accuracy, -163 dBm tracking sensitivity
Integrated GPS Module with LNA	u-blox MAX-M8 series Concurrent GNSS Module (u-blox.com)

GPS Antenna	<p>SMA-Female connector for external Passive antenna (External)</p> <p>MMCX-Female connector for external Passive antenna (Embedded)</p> <p><i>(use of Active GPS antenna is not recommended)</i></p>
Integrated CPU	MIPS 24Kc, 540 MHz, 32MB Flash, 64MB DDR2 RAM
ESD Protection	IEC 61000-4-2 test criteria, Level 3 (± 6 KV) for Contact Discharge and Level 4 (± 15 KV) for Air Discharge
MTBF	>235k hours (25 years)
Life Cycle Planning	Extended lifespan with 7 years guaranteed availability
REGULATORY INFORMATION	
Regulatory Requirements	Designed and verified to meet various regulatory requirements. Formal testing and approval are required for the Integrator's antenna type. The Integrator is responsible for obtaining all regulatory approvals in target markets for the finished product.
RoHS/WEEE Compliance	Yes. 100% Recyclable/Biodegradable packaging
EXPORT INFORMATION	
ECCN Code	5A992
HS Code	85256010

ADDITIONAL RF SPECIFICATIONS

MCS Rate	Modulation	Combined Output Power (dBm)	Sensitivity (dBm)	UDP Throughput (Mbps)
0	BPSK (1/2)	30	-93	5.4
1	QPSK (1/2)	29	-90	10.62
2	QPSK (3/4)	29	-88	15.66
3	16-QAM (1/2)	29	-85	20.52
4	16-QAM (3/4)	27	-80	29.88
5	64-QAM (2/3)	26	-78	38.88
6	64-QAM (3/4)	25	-75	43.11
7	64-QAM (5/6)	24	-72	47.34
8	BPSK (1/2)	30	-90	10.53
9	QPSK (1/2)	29	-86	20.43
10	QPSK (3/4)	29	-84	29.7
11	16-QAM (1/2)	29	-81	38.52
12	16-QAM (3/4)	27	-77	54.72
13	64-QAM (2/3)	26	-73	69.3
14	64-QAM (3/4)	25	-72	76.14
15	64-QAM (5/6)	24	-71	82.8

Note 1: Performance based on 20-MHz bandwidth

Note 2: Sensitivity and throughput are approximately proportional to bandwidth.

