

Doodle Labs RM-2100-42M Mesh Rider Radio

Overview

The RM-2100-42M Mesh Rider Radio is an advanced MANET data-link. The 1370 MHz and 2100-2500 MHz bands are supported allowing it to be used in various federal applications.

The RM-2100-42M employs Doodle Labs' patented Mesh Rider® technology with state-of-the-art RF and networking capabilities that enable communication further, faster, and more reliably than any comparable solution on the market. For example, optimized video streaming carries crystal clear 4K video while simultaneously carrying low latency command and control data.

The interoperable Mesh Rider Radio platform is available in many frequency bands between 600 MHz and 6 GHz in Nano, Mini, OEM, Embedded, Wearable and External form factors. This flexibility allows customers to use their industry specific frequency bands for deploying private wireless networks that encompass all the use cases for human and machine collaboration.

For more information, please visit: <https://doodlelabs.com/smart-radio/>

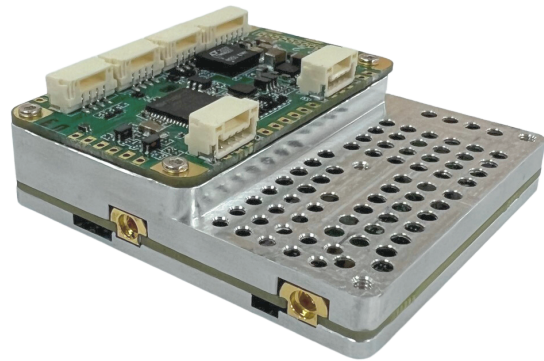

Frequency Bands

| Band | Frequency Range |
|-----------------|---|
| 1370-MHz | 1350 MHz to 1390 MHz Federal Band |
| 2245-MHz | 2200 MHz to 2290 MHz Federal Band M3 |
| 2350-MHz | 2310 MHz to 2390 MHz Federal Band M4 |
| 2450-MHz | 2400-MHz to 2500 MHz Federal Band M6 |

Key Features - Mesh Rider Radio Platform

PERFORMANCE RF

- Long range (field tested >100km) and high throughput (up to 100 Mbps) Mesh Rider waveform
- Interference resistant COFDM for robust link quality in difficult RF environments
- Exceptional Multipath and NrLOS MIMO performance
- Adaptive radio modulations from BPSK up to 64QAM, with fast per packet optimization to maximize link performance in dynamic environments
- Software defined channel bandwidth for efficient re-use of spectrum
- Convolutional coding, Forward Error Correction (FEC), ACK-retransmits, Maximal Ratio Combining, Spatial Multiplexing, and Space Time Block Coding for robust data transmission over noisy channel/spectrum
- Single channel, Time Division Duplexing (TDD) for bi-directional traffic
- Resistant to high-power jamming signals
- ATPC for widely dispersed mesh network
- Built-in Spectrum Scanner to help mitigate interference issues

PERFORMANCE NETWORKING

- Ultra-Reliable Low Latency Channel (URLLC) for Command and Control
- Optimized video streaming channel for Unicast and Multicast transport
- FIPS Certified AES 256- and 128-bit encryption
- End-to-end IP architecture with Ad Hoc, WDS transparent bridge, Client, AP, and

- Self-healing/self-forming multi-frequency mobile mesh for highly reliable network with redundancy

Internet Gateway operating modes

- Embedded network management APIs

ADDITIONAL FEATURES

- Very small size, weight, and power for mobile applications
- Ethernet, USB, and UART interfaces to allow easy integration into different system architectures
- Leverage the benefits of the most extensible OpenWrt ecosystem and install 3rd party IoT applications
- Rugged, vibration resistant construction to meet MIL-specs
- MIL-spec temp range (-40C to +85C)
- High quality, manufactured in ISO 9001 and ISO 14001 certified facilities
- COTS - Commercial off the Shelf
- Extended lifespan and availability

System Integration

The Mesh Rider Radio has been designed to be plug and play. Only USB and a power supply are required for integration.

Visit [Doodle Labs Technical Library](#) for extensive design-in documents.

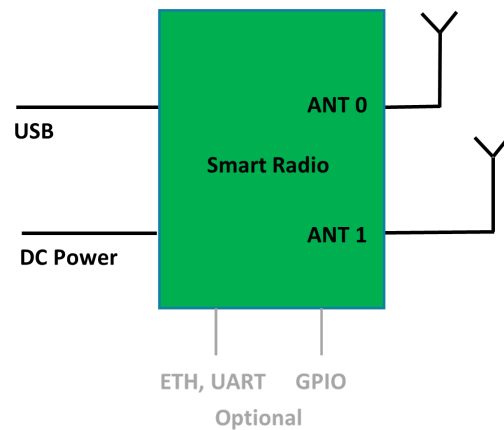

Technical Specifications (1370 MHz and 2100-2500 MHz)

| | |
|--|--|
| Model Category | XTreme |
| ORDERING CODES | |
| Radio Configuration | 2x2 MIMO |
| Model # | RM-2100-42M3 |
| Antenna (Optional) | ANT-2100-3-O |
| Evaluation Kit (Optional) | EK-2100-42: 2x Multi-band Antenna, Breakout board, Cables |
| Design-In Documentation | Doodle Labs Technical Library |
| PERFORMANCE OVERVIEW | |
| Data Throughput at 10-meter range with Attached 3 dBi Antennas (Indicative) | 80 Mbps (20 MHz Channel) 40 Mbps (10 MHz Channel) 20 Mbps (5 MHz Channel) 12 Mbps (3 MHz Channel) |
| Over the Air Data Encryption | 128-bit AES (Full throughput) 256-bit AES (12 Mbps max throughput) |
| FIPS Certification (Optional) | FIPS 140-3 |
| Operating Modes | Mesh, WDS AP, WDS Client Bridged or Internet Gateway with NAT |
| Command & Control channel | Ultra-Reliable Low Latency Channel (URLLC). Latency 1.5-10 ms |
| Video Channel | Optimized video streaming with Unicast and Multicast transmission |
| RF SPECIFICATIONS | |

| | |
|---|---|
| Protocol Compatibility | Fully compatible with Doodle Labs Mesh Rider Waveform |
| Frequency Range | 1370 MHz and 2100-2500 MHz |
| Operating Bands (Software Selectable) | 1350-1390 MHz M4 = 2200-2290 MHz M5 = 2310-2390 MHz M6 = 2400-2510 MHz ISM = 2402-2482 MHz |
| Advanced Band Filters | Dedicated SAW filters for each band for high interference immunity |
| Max RF Power at SMA port (Software control) Each radio individually calibrated | 1.0W (30 dBm) @ MCS 0,8 0.8W (29 dBm) @ MCS 3,11 0.5W (27 dBm) @ MCS 5,13 250mW (24 dBm) @MCS 7,15 |
| Channel Sizes (Software Selectable) | 3, 5, 10, 20 MHz |
| Radio Data Rate | Auto adapting Modulation Coding Scheme (MCS0-15) |
| Antenna Signal Strength | -30 to -90 dBm (Recommended), Absolute Maximum= +12 dBm |
| Receiver LNA Gain | 15 dB |
| RF Power Control | In 1 dBm steps, Tolerance ± 1 dBm |
| Automatic Transmit Power Control (ATPC) | Intelligently adjusts the transmit power for very close range operation |
| Integrated Antenna Port Protection | Able to withstand open port, >10 KV (contact) and >15KV (open air discharge) as per IEC-61000-4-2 |
| Wireless Error Correction | FEC, ARQ |
| Receive Noise Figure | +4 dB |

| | |
|--|---|
| Receive Adjacent Channel Rejection (ACRR) | 34 dB @ MCS0 for 20 MHz channel (Typ) |
| Transmitter Adjacent Channel Leakage Ratio (ACLR) | < 28 dBr (Fc ± ChBW) |
| Transmitter Spurious Emission Suppression | < 40 dBc |
| Frequency Accuracy | ±10 ppm max over life |
| NETWORKING SPECIFICATIONS | |
| Mesh Router | Self-Forming/Self-Healing, Peer to Peer |
| Custom Software Package Manager | Image Builder, OPKG, ipk |
| Radio Management | Web GUI (HTTPs), SSH and JSON-RPC |
| Access control | Password, MAC, IP, Port filtering |
| Supported Protocols | IPv6, QoS, DNS, HTTPs, IP, ICMP, NTP, DHCP |
| Software Upgrade | Over the air software upgrade supported |
| HARDWARE SPECIFICATIONS | |
| Power Input | 5V ± 5% |
| DC Power Consumption | <p>1370-MHz: Average 7W (50% Tx/Rx duty cycle), 10W Peak Tx power @ max range, 4.5W Rx mode</p> <p>2100-2510-MHz: Average 5W (50% Tx/Rx duty cycle), 8W Peak Tx power @ max range, 2W Rx mode</p> |

| | |
|--|---|
| Dimensions | Baseband: 47 x 28 x 5 mm RF Board: 46 x 51 x 6.5 mm 36.5 grams |
| Mesh Rider Antenna Ports | 2x MMCX-Female Connector |
| Host Interface | Ethernet (100 Base-T), 1x USB -Dev (Ethernet over USB only), 1x UART (3.3V), 1x USB-H, 3x GPIO |
| Temperature range (Operating) | Industrial: -40°C to +85°C <i>* System's thermal design should ensure that the radio's case temperature is maintained within these specifications.</i> |
| Temperature range (Non-Operating) | -40°C to +100°C |
| Ingress Protection | IP 50, Dust Protected, No Liquid protection |
| Relative Humidity | 5% to 95% noncondensing |
| Shock and Vibration Resistance | Compliant to MIL-STD-810H for high shock and vibration |
| Reliability | Extreme Reliability, IPC Class 2 standard with Class 3 options |
| Integrated CPU | MIPS 24Kc, 540 MHz, 32MB Flash, 64MB DDR2 RAM |
| ESD Protection | IEC 61000-4-2 test criteria, Level 3 (±6KV) for Contact Discharge and Level 4 (±15KV) for Air Discharge |
| MTBF | >235k hours (25 years) |
| Life Cycle Planning | Extended lifespan with 7 years guaranteed availability |
| REGULATORY INFORMATION | |
| J/F-12 Certification | N.A. |
| FCC ID | TBD |

| | |
|--------------------------------|---|
| Industry Canada (IC) | TBD |
| CE | TBD |
| Regulatory Requirements | Designed and verified to meet various regulatory requirements. Formal testing and approval are required for the Integrator's antenna type. The Integrator is responsible for obtaining all regulatory approvals in target markets for the finished product. |
| RoHS/WEEE Compliance | Yes. 100% Recyclable/Biodegradable packaging |
| EXPORT INFORMATION | |
| ECCN Code | 5A992 |
| HS Code | 85256010 |

ADDITIONAL RF SPECIFICATIONS

| MCS Rate | Modulation | Combined Output Power (dBm) | Sensitivity (dBm) | UDP Throughput (Mbps) |
|-----------------|-------------------|------------------------------------|--------------------------|------------------------------|
| 0 | BPSK (1/2) | 30 | -93 | 5.4 |
| 1 | QPSK (1/2) | 29 | -91 | 10.62 |
| 2 | QPSK (3/4) | 29 | -89 | 15.66 |
| 3 | 16-QAM (1/2) | 29 | -87 | 20.52 |
| 4 | 16-QAM (3/4) | 28 | -83 | 29.88 |
| 5 | 64-QAM (2/3) | 27 | -79 | 38.88 |
| 6 | 64-QAM (3/4) | 26 | -77 | 43.11 |
| 7 | 64-QAM (5/6) | 24 | -75 | 47.34 |
| 8 | BPSK (1/2) | 30 | -90 | 10.53 |
| 9 | QPSK (1/2) | 29 | -88 | 20.43 |
| 10 | QPSK (3/4) | 29 | -86 | 29.7 |
| 11 | 16-QAM (1/2) | 29 | -84 | 38.52 |
| 12 | 16-QAM (3/4) | 28 | -80 | 54.72 |
| 13 | 64-QAM (2/3) | 27 | -76 | 69.3 |
| 14 | 64-QAM (3/4) | 26 | -74 | 76.14 |
| 15 | 64-QAM (5/6) | 24 | -72 | 82.8 |

Note 1: Performance based on 20-MHz bandwidth

Note 2: Sensitivity and throughput are approximately proportional to bandwidth.

