

Wearable Mesh Rider Radio – 2400~2482 MHz (WiFi Band)

Overview

The Wearable Mesh Rider Radio brings private wireless networking and dynamic mesh capabilities to connected workers. Each device is a node on a long-range Mesh Rider network and uses WiFi to bridge Tablets and Smartphones onto the network. The Wearable Mesh Rider Radio is used by tactical teams to collaborate by streaming voice, video, and data on a fast, low latency, and encrypted network.



The Wearable Mesh Rider Radio was designed to be conveniently carried. Embedded antennas are capable of streaming HD video to a teammate up to 1 km away. External antenna ports are included to integrate with high-gain antennas for longer distances. The radio can be powered by a variety of sources, including tablets and standards-based battery banks. It is also available in an OEM form factor for embedded use cases.

As with all Mesh Rider Radio form factors, the Wearable is available in many frequency bands between 900 MHz and 6 GHz frequency range. This flexibility allows customers to use their industry specific frequency bands for deploying private wireless networks.

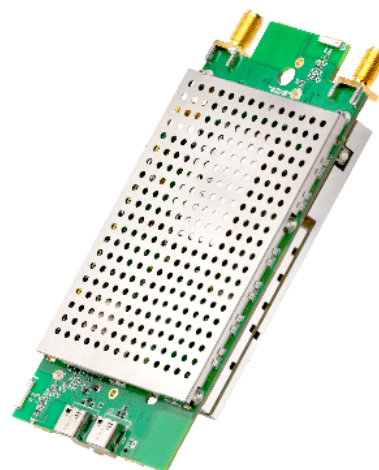

The Mesh Rider Radio employs Doodle Labs' patented Mesh Rider® technology with state-of-the-art RF and networking capabilities that enable communication further, faster, and more reliably than any comparable solution on the market. For example, optimized video streaming carries crystal clear 4K video while simultaneously carrying Ultra Reliable Low Latency (URLLC) command and control (C&C) data for machines.

For more information, please visit: <https://doodlelabs.com/smart-radio/>

Key Features - Mesh Rider Radio Platform

PERFORMANCE RF

- Long range (field tested >100km) and high throughput (up to 100 Mbps) Mesh Rider waveform
- Interference resistant COFDM for robust link quality in difficult RF environments
- Exceptional Multipath and NrLOS MIMO performance
- Adaptive radio modulations from BPSK up to 64QAM, with fast per packet optimization to maximize link performance in dynamic environments
- Software defined channel bandwidth for efficient re-use of spectrum
- Convolutional coding, Forward Error Correction (FEC), ACK-retransmits, Maximal Ratio Combining, Spatial Multiplexing, and Space Time Block Coding for robust data transmission over noisy channel/spectrum
- Single channel, Time Division Duplexing (TDD) for bi-directional traffic
- Resistant to high-power jamming signals
- ATPC for widely dispersed mesh network
- Built-in Spectrum Scanner to help mitigate interference issues

PERFORMANCE NETWORKING

- Ultra-Reliable Low Latency Channel (URLLC) for Command and Control
- Optimized video streaming channel for Unicast and Multicast transport
- Self-healing/self-forming multi-frequency mobile mesh for highly reliable network with redundancy
- FIPS Certified AES 256- and 128-bit encryption
- End-to-end IP architecture with Ad Hoc, WDS transparent bridge, Client, AP, and Internet Gateway operating modes
- Embedded network management APIs

ADDITIONAL FEATURES

- Very small size, weight, and power for mobile applications
- Ethernet, USB, and UART interfaces to allow easy integration into different system architectures
- Leverage the benefits of the most extensible OpenWrt ecosystem and install 3rd party IoT applications
- Rugged, vibration resistant construction to meet MIL-specs
- MIL-spec temp range (-40C to +85C)
- High quality, manufactured in ISO 9001 and ISO 14001 certified facilities
- COTS - Commercial off the Shelf
- Extended lifespan and availability

System Integration

The Mesh Rider Radio has been designed to be plug and play. Only USB and a power supply are required for integration.

Visit [Doodle Labs Technical Library](#) for extensive design-in documents.

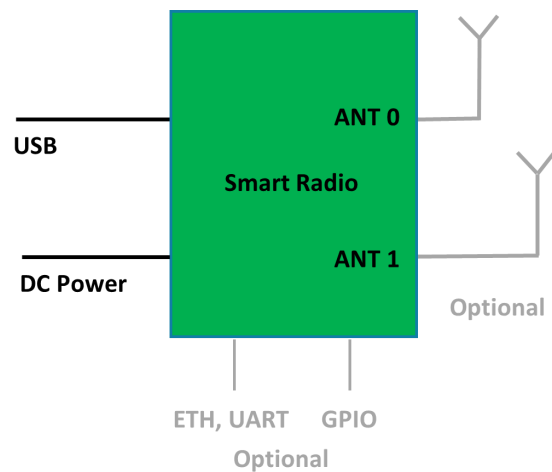

Technical Specifications (2400~2482 MHz, WiFi band)

Model Category	XTreme
ORDERING CODES	
Radio Configuration	2x2 MIMO
Model # (Wearable)	RM-2450-2K-XW RM-2450-2K-XW-C RM-2450-2K-XWE (does not include internal Mesh Rider antennas, Altimeter and GPS functionalities) RM-2450-2K-XWE-C (does not include internal Mesh Rider antennas, Altimeter and GPS functionalities)
Model # (OEM)	RM-2450-2K-XO RM-2450-2K-XO-C
Evaluation Kit (Optional)	EK-2450-2K Includes: 2x Attached Antennas for Mesh Rider, Breakout board, Cable, Mounting plate
Design-In Documentation	Doodle Labs Technical Library
PERFORMANCE OVERVIEW	
Data Throughput at 10-meter range with Attached 3 dBi Antennas (Indicative)	80 Mbps (20 MHz Channel) 40 Mbps (10 MHz Channel) 20 Mbps (5 MHz Channel) 12 Mbps (3 MHz Channel)
Over the Air Data Encryption	128-bit AES (Full throughput) 256-bit AES (12 Mbps max throughput)
FIPS Certification (Optional)	FIPS 140-3
Operating Modes	WiFi Radio: AP, Client Mesh, WDS AP, WDS Client Bridged or Internet Gateway with NAT

Command & Control channel	Ultra-Reliable Low Latency Channel (URLLC). Latency 1.5-10 ms
Video Channel	Optimized video streaming with Unicast and Multicast transmission
RF SPECIFICATIONS	
Protocol Compatibility	Fully compatible with Doodle Labs Mesh Rider Waveform
Frequency Range	2400-2482 MHz
Advanced Band Filters	Dedicated SAW filters for high interference immunity
Max RF Power at SMA port (Software control) Each radio individually calibrated	1.0W (30 dBm) @ MCS 0,8 0.8W (29 dBm) @ MCS 3,11 0.4W (26 dBm) @ MCS 5,13 250mW (24 dBm) @MCS 7,15
Channel Sizes (Software Selectable)	3, 5, 10, 20 MHz
Radio Data Rate	Auto adapting Modulation Coding Scheme (MCS0-15)
Antenna Signal Strength	-25 to -85 dBm (Recommended), Absolute Maximum= +12 dBm
RF Power Control	In 1 dBm steps, Tolerance ± 1 dBm
Automatic Transmit Power Control (ATPC)	Intelligently adjusts the transmit power for very close range operation
Integrated Antenna Port Protection	Able to withstand open port, >10 KV (contact) and >15KV (open air discharge) as per IEC-61000-4-2
Wireless Error Correction	FEC, ARQ
Receive Noise Figure	+4 dB
Receive Adjacent Channel Rejection (ACRR)	34 dB @ MCS0 for 20 MHz channel (Typ)

Transmitter Adjacent Channel Leakage Ratio (ACLR)	< 28 dBr (Fc ± ChBW)
Transmitter Spurious Emission Suppression	< 40 dBc
Frequency Accuracy	±10 ppm max over life
WI-FI HOTSPOT SPECIFICATIONS	
WiFi Standard	IEEE 802.11n, 2x2 MIMO
Frequency Range	2400-2482 MHz 5160-5895 MHz
RF Power Output (Typ)	50 mW (17 dBm) EIRP
Channel Size	20 MHz
Radio Data Rate	Auto adapting Modulation Coding Scheme (MCS 0-15)
Antenna Signal Strength	-25 to -85 dBm (Recommended), Absolute Maximum= +12 dBm
RF Power Control	In 1 dBm steps, Tolerance ±1 dBm
Wireless Error Correction	FEC, ARQ
NETWORKING SPECIFICATIONS	
Mesh Router	Self-Forming/Self-Healing, Peer to Peer
Custom Software Package Manager	Image Builder, OPKG, ipk
Radio Management	Web GUI (HTTPs), SSH and JSON-RPC
Access control	Password, MAC, IP, Port filtering
Supported Protocols	IPv6, QoS, DNS, HTTPS, IP, ICMP, NTP, DHCP

Software Upgrade	Over the air software upgrade supported
HARDWARE SPECIFICATIONS	
Power Input	6V - 24V, USB-PD Compliant
DC Power Consumption	14W @ Max Data Troughput 12W @ Max Range 3.5W in Rx mode 2W in Standby mode
Dimensions: Wearable	130 x 75 x 23 mm and 245 grams
Dimensions: OEM	127 x 63 x 13 mm and 125 grams
Mesh Rider Antenna Ports	2x Embedded Antennas and 2x SMA-Female connectors for Attached/External antennas
Host Interface	USB-Dev, Ethernet (100 Base-T), 1x UART (3.3V), USB-Host, and 1x GPIO port (2.62V)
Temperature range (Operating)	External Temp: Up to +40°C (Wearable) Industrial: -40°C to +85°C Commercial Operating Temp Range: -10°C to +65°C <i>* System's thermal design should ensure that the radio's case temperature is maintained within these specifications.</i>
Temperature range (Non-Operating)	-40°C to +100°C
Ingress Protection	IP51, protected against dust and rainfall
Relative Humidity	5% to 95% non-condensing
Shock and Vibration Resistance	Compliant to MIL-STD-810H for high shock and vibration
Reliability	Extreme Reliability, IPC Class 2 standard with Class 3 options

WiFi Hotspot Antennas	2x Embedded Antennas
GPS Features	<p>Simultaneous multiple constellations (GPS/SBAS/Galileo/Glonass/BeiDou/QZSS)</p> <p>Receive Sensitivity -167 dBm, Max. Velocity 500m/sec ± 0.05m/S, Heading ± 0.3 degrees, Position Accuracy 2m</p>
Integrated GPS Module with LNA	u-blox MAX-M8 series Concurrent GNSS Module (u-blox.com)
GPS Antenna	<p>Embedded Antenna</p> <p>+ SMA-Female connector for external Passive antenna (use of Active GPS antenna is not recommended)</p>
Integrated Altimeter	-698 to +11,775 m (20-bit), 1 Hz Refresh Rate. MPL3115A2
Integrated Temp Monitor	-40 to +85 C MPL3115A2
Integrated CPU	MIPS 24Kc, 540 MHz, 32MB Flash, 64MB DDR2 RAM
ESD Protection	IEC 61000-4-2 test criteria, Level 3 (±6KV) for Contact Discharge and Level 4 (±15KV) for Air Discharge
MTBF	>235k hours (25 years)
Life Cycle Planning	Extended lifespan with 7 years guaranteed availability
REGULATORY INFORMATION	
J/F-12 Certification	J/F # 11929 (NTIA DD1494 available upon request)
Regulatory Requirements	Designed and verified to meet various regulatory requirements. Formal testing and approval are required for the Integrator's antenna type. The Integrator is responsible for obtaining all regulatory approvals in target markets for the finished product.
RoHS/WEEE Compliance	Yes. 100% Recyclable/Biodegradable packaging

EXPORT INFORMATION**ECCN Code** 5A992**HS Code** 85256010

ADDITIONAL RF SPECIFICATIONS

MCS Rate	Modulation	Combined Output Power (dBm)	Sensitivity (dBm)	UDP Throughput (Mbps)
0	BPSK (1/2)	30	-93	5.4
1	QPSK (1/2)	29	-91	10.62
2	QPSK (3/4)	29	-89	15.66
3	16-QAM (1/2)	29	-87	20.52
4	16-QAM (3/4)	28	-83	29.88
5	64-QAM (2/3)	27	-79	38.88
6	64-QAM (3/4)	26	-77	43.11
7	64-QAM (5/6)	24	-75	47.34
8	BPSK (1/2)	30	-90	10.53
9	QPSK (1/2)	29	-88	20.43
10	QPSK (3/4)	29	-86	29.7
11	16-QAM (1/2)	29	-84	38.52
12	16-QAM (3/4)	28	-80	54.72
13	64-QAM (2/3)	27	-76	69.3
14	64-QAM (3/4)	26	-74	76.14
15	64-QAM (5/6)	24	-72	82.8

Note 1: Performance based on 20-MHz bandwidth

Note 2: Sensitivity and throughput are approximately proportional to bandwidth.

